

LET US SPIN WITH SABAR SPIN

## **SABAR**

- > SPINNING CANS
- > CASTOR WHEELS
- > TROLLEY



**SABAR**

**SABAR SPINMATIC EQUIPMENTS**

*Beyond The Conventional*

## 4 DECADES OF EXPERIENCE...

**Sabar Spinmatic Equipments**, India the market leader of Spinning Roll Shop Machinery since 1969 now highly delighted to offer impeccable quality Spinning Cans, its accessories & Trolleys.



# **SABAR**

## **> SPINNING CANS**

**SabarSpin Sliver cans** are made from Virgin quality high density polyethylene sheets. Seamless card cans collect sliver from Carding, Drawing, Roving and Open-end spinning. The Cans are available in size range of 400 mm to 1000 mm diameter and 800 mm to 1500 mm height.

Available Colour for Can:



Violate

Natural  
Blue

Sky  
Blue

Green

Parrot  
Green

Golden  
Yellow

Orange

Red

Pink

Baby Pink

Natural  
White



## **SABAR**

### > ROPE DYEING CAN

These cans are specially developed for Denim manufacturers who use Rope Dyeing Plants.

**Dimensions:** 1500 mm diameter and 1750 mm height



#### **CYLINDRICAL BODY:**

- > Made from Virgin quality High Density polyethylene sheets ensures smooth finish & cylindrical integrity which prevents sliver damage by rubbing.

#### **SPRINGS:**

- > Made from high carbon spring steel wire of grade II.
- > Pre tension springs are tested and filled with anti-slip surface ABS/PP/GI top plate and joined by PVC coated steel wire rope with steel base.
- > Plastic moulded brackets are provided on top plate for height adjustment.
- > For Cans of diameter 600 mm and above, stabilised pantograph springs are recommended which carries higher load of springs.

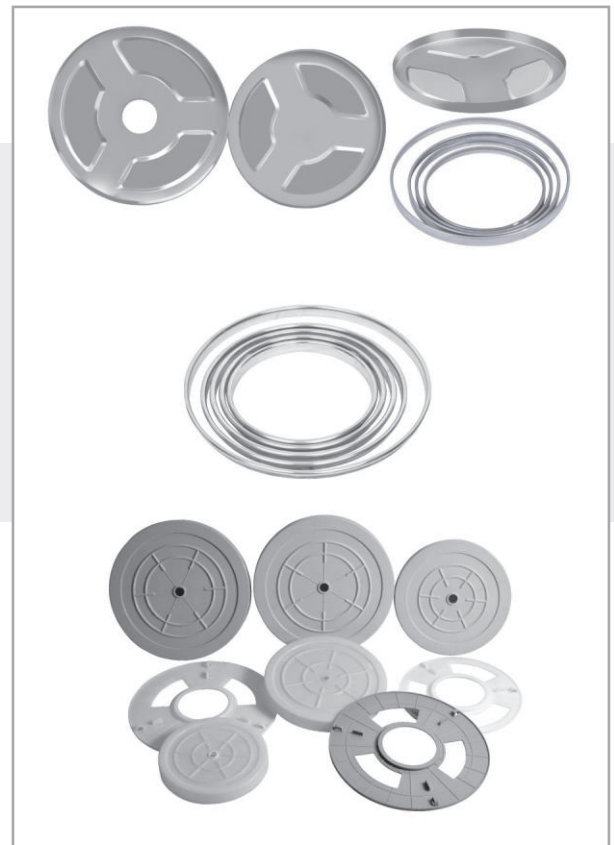

#### **BOTTOM PLATES & RING:**

- > Bottom plate and ring give support to the cans and hold the balance.
- > Bottom plates having castor fitting arrangements are supplied.
- > Bottom rings are made from angles and are welded with rod rings.

#### **TOP RING:**

- > The bands are swaged with top ring making the top robust and to hold cans firmly to the right shape.

#### **TOP PLATE & SPRING PLATE:**

- > Top plate & spring plate are made from unbreakable polymers and galvanised electro steel with anti slip surface.
- > Top plate has a friction surface to anchor the initial coils of sliver preventing throw-out.

# SABAR

## > CASTOR WHEELS







Sabar Spinmatic Equipments offers wide range of castors starting from 2" to 10" and with a load capacity ranging from 30 kg to 300 kg.

**Material:** Castor body made from CRCA material and stainless steel.

**Plating:** Zinc plating in different shades like silver, blue, golden yellow, Olive green. Powder coating in black colour.

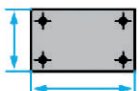
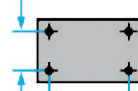
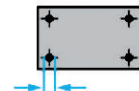

in mm

								
60	60	25	83 x 68	64 x 52	7	58	85	60
65	65	30	70 x 65	50 x 50	7	66	87	65
80	80	30	91 x 77	72 x 51	7	80	103	80
120	120	34	125 x 100	98 x 76	11 x 14	117	162	120

**SABAR**

> TROLLEY

**Model No. SabarSpin 101**

**Application:**

Transportation for bobbins, Doffing and roving bobbins at Simplex.



**Model No. SabarSpin 102**

**Application:**

Transport all types of bobbins and also for Steaming, Humidifying and controlling of bobbin.

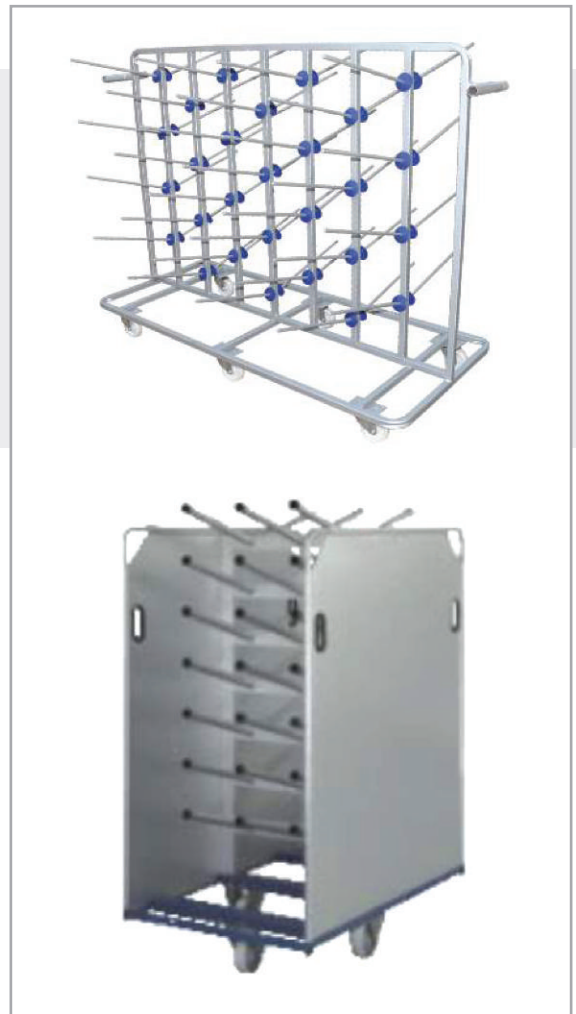

**Model No. SabarSpin 103**

**Application:**

Arbour Transportation Trolley. Purpose for transport of grind and ungrind arbour.



Global Representation By:



**SABAR**

**SABAR SPINMATIC EQUIPMENTS**

*Beyond The Conventional*

11, Rupak Society, St. Xavier's School (Loyalla Hall) Road,  
Nr. Devkinandan Jain Temple, Post Navjivan, Ahmedabad 380014, Gujarat, INDIA.

☎ +91-99133 63389, +91 98250 26598 📞 +91-79-27683024

✉ sales@sabarspinmatic.com 🌐 www.sabarrollshop.com



- > **Spinning Roll Shop Machinery**
- > **Spinning Cans, its accessories and trolleys**
- > **Hydraulic Cotton Baling Press machine**

**Let us Spin with**

**SABAR SPIN !!!**